

6032100011

Tanque de Encastre_Built-in Toilet Flushing Mechanism Tank
Cisterna para Batsidor empotrable_Réservoir pour cuvette



Características
Features
Características
Caractéristiques

Dimensões_Dimensions_Dimensions_Dimensions

428 x 849 x 92

Material_Material_Matériau_Material

Metal/ HDPE

Descarga_Flush_Descarga_Chasse

3L/ 6L

Peso_Weight_Peso_Poids

3 KG

Embalagem_Package_Caja_Embalage

3,8 KG | 870 x 490 x 95

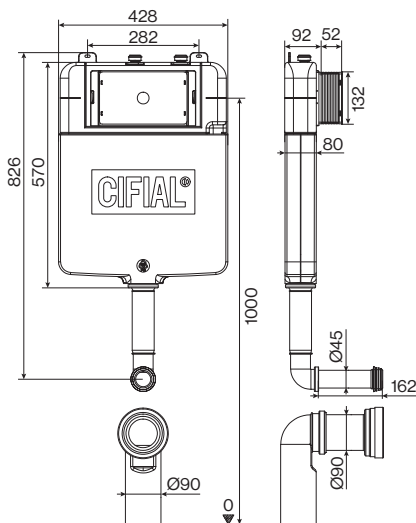

Slim 80mm



3L/6L | EN997



0.2 a 10 bar



Ligação água G 1/2"
Water connection G 1/2"
Conexión de agua G 1/2"
Raccordement de l'eau G 1/2"



Paredes de alvenaria
Masonry walls
Muros de mampostería
Murs en maçonnerie



Paredes ligeiras
Plasterboard walls
Muros de cartón yeso
Murs en plaques de plâtre



Fácil Montagem
Easy Assembly
Fácil montaje
Assemblage facile



Testado e Controlado
Tested and Controlled
Probado y controlado
Testé et contrôlé



Serviço Pós-venda
After Sales Service
Servicio Postventa
Service Après-vente



5 Anos Garantia
5 Year Guarantee
5 años de garantía
Garantie de 5 ans

Peças Sobresselentes

Spare Parts

Piezas de Recambio

Pièces Détachées

REF.

6039020010

Kit hastas acionamento e fecho
Mechanic outlet valve
Palanca de la válvula de descarga
Mécanisme de chasse

6039040010

Torneira Enchimento G 1/2"
Inlet valve G 1/2"
Flotador G 1/2"
Robinet flotteur

6039050010

Válvula de Descarga
Outlet valve
Válvula de Descarga
Bloc support



Catálogo/ Catalogue

CIFIAL S.A.

Rua da Circunvalação n.º210, Abelheira
4520-461 Rio Meão | Portugal

Tel. +351 256 780 100 | Fax. +351 256 783 395
encomendas@cifial.pt | comercial@cifial.pt

CIFIAL UK LTD

7 Faraday Court | Park Farm Industrial Estate
Wellingborough | Northants NN8 6XY | UK

Tel. +44 1933 402 008 | Fax. +44 1933 402 063
sales@cifial.co.uk



www.cifial.pt



www.cifial.co.uk